Table of Contents

E70 Energy Management

Subject	Page
The Energy Circuit in the Vehicle	5
Power Management	6
Idle Speed Boost	6
Charging Voltage Target Value	6
Emergency Operation	7
APM Control System	7
Electric Load Reduction	7
Fuel Consumption Reduction Measures	8
Advanced Power Management	9
Energy Flow	9
Information Flow	10
Diagnosis Information	11
Vehicle in Stationary Mode (terminal R and terminal 30)	12
Electric Loads in Stationary Mode	12
Stationary Load Log-off	12
Terminal 30g and Terminal 30g_f	12
Terminal 30g and Terminal 30g_f relay	14
Time-dependent Deactivation	14
Fault-dependent Deactivation	14
Terminal 30g_f Relay Switch-on and off Conditions	14
Continuous Positive	15
General Measures	16
Components	17
Intelligent Battery Sensor (IBS)	17
Junction Box	19
Engine Management (Power Management)	20
Transport Mode	21
Closed-circuit Current	23
Electrical System and Battery Diagnosis	24
Energy Management - Diagnosis in Vehicle	25
Energy History Memory	27
Memory Cycle	27
Driving Profile and Stopped Profile	27
Sleep Blockers	28
Bus Wake-ups	28
Intact Vehicle	29

Subject	Page
Defective Vehicle	30
Data Record	33
Sleep Blockers	33
Number of bus wake-ups, driving profile/stopped profile	33
Bus Wake-up IDs	34
Data Record Storage	34
Ring Memory	35

BLANK
PAGE

Energy Management

Model: E70

Production: From Start of Production

OBJECTIVES

After completion of this module you will be able to:

- Locate and Identify Energy Management System Components
- Understand E70 Energy Management

The Energy Circuit in the Vehicle

As in the current models, an energy management system is used in the E70 to ensure balanced energy management in the vehicle.

The energy management functions are integrated in the power management system that is implemented in the form of software in the engine control unit.



Index	Explanation
1	Engine
2	Alternator
3	Intelligent Battery Sensor
4	Battery
5	Junction Box
6	Electrical load (i.e. headlights)
7	Engine management with integrated power management

Power Management

The power management establishes the control processes in the area of energy management of our vehicles.

A basic distinction is made between two types of power management:

- Basic Power Management (BPM)
- Advanced Power Management (APM)

Only the advanced power management APM is used in the E70.

In addition to the main functions of the basic power management, idle speed and of charging voltage target value, this system includes the following expanded functions:

- Electric load reduction
- Electric load shut-down
- Vehicle systems diagnosis
- Battery diagnosis

Idle Speed Boost

Despite the alternator operating at maximum, on gasoline engine vehicles the idle speed is increased by up to 200 rpm as soon as current is drawn from the battery.

Charging Voltage Target Value

The charging voltage at the alternator is controlled dependent on the temperature. The temperature value is made available by the Intelligent Battery Sensor (IBS).

The power management uses this value as the input variable for calculating the battery temperature. With the aid of a calculation model, the specified charging voltage is set based on the battery temperature.

This information is sent to the alternator via the Bit-serial Data Interface (BSD).

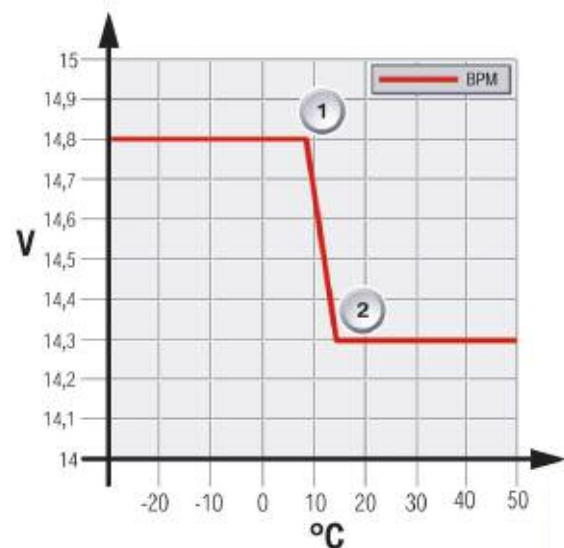

Index	Explanation
1	Model- based battery temperature of 8 degrees Celsius
2	Model- based battery temperature of 15 degrees Celsius

Emergency Operation

The APM makes use of emergency operation functions when there is a break in the BSD interface. In this case, the alternator voltage is set to a constant 14.3 V. A fault code "Communication BSD" is entered in the fault code memory of the engine management.

APM Control System

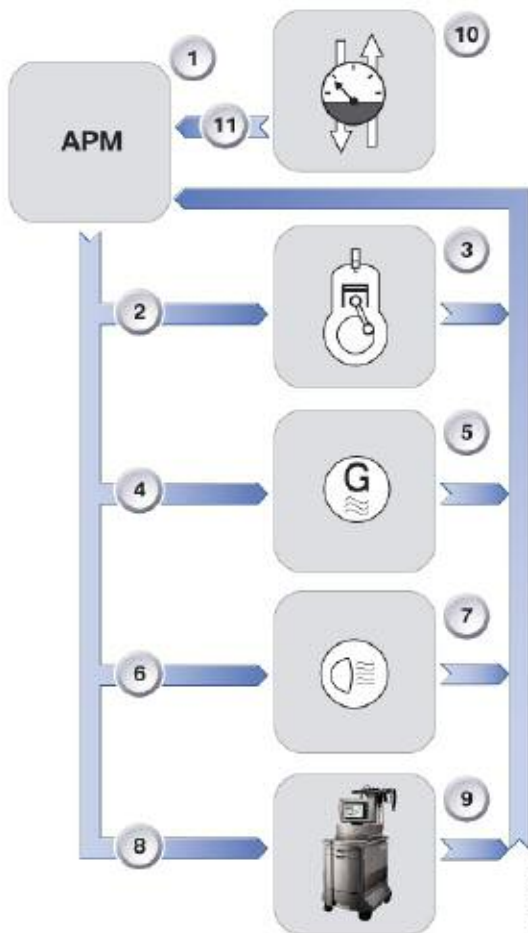

Index	Explanation
1	Advanced Power Management
2	Idle Speed Boost
3	Engine
4	Charging voltage target value
5	Alternator
6	Electrical load reduction
7	Electrical loads
8	Electrical system and battery diagnosis
9	BMW diagnostic system
10	Intelligent battery sensor
11	Battery data

Electric Load Reduction

When the vehicle is equipped with APM (advanced power management), in addition to increasing the idle speed and the specified charging voltage, the output of various electric loads can be reduced or the loads can be switched off in order to reduce the power consumption in critical situations.

The electric loads are shut down only under the following two conditions:

- Battery charge status in critical range
- Alternator fully utilized

Fuel Consumption Reduction Measures

The following measures are activated under these preconditions:

Sequence	Function	Operation	Control Unit
1	Rear Window	Clocking	IHKA
2	Seat Heating, rear compartment	Stage 2	FKA
3	Electrical auxiliary heater, rear compartment	75 %	FKA
4	Seat heating, front	Stage 2	SMBFA SMBF JB
5	Seat heating, rear compartment	Stage 1	FKA
6	Electrical auxiliary heater, rear compartment	50 %	FLA
7	Seat heating, front	50 %	SMBFA SMBF JB
8	Electrical auxiliary fan, 3rd row seating	50 %	IHKA
9	Heater blower	75 %	IHKA/FKA
10	Electrical auxiliary heater, rear compartment	25 %	FKA
11	Steering wheel heating	OFF	FRM/JB
12	Electrical auxiliary heater, rear compartment	OFF	FKA
13	Mirror heating	OFF	FRM/JB
14	Active seat	OFF	SMFA SMBF
15	Steering wheel heating	OFF	IHKA
16	Electrical auxiliary fan, 3rd row seating	OFF	IHKA
17	Seat heating, front	OFF	SMFA SMBF JB
18	Seat heating, rear compartment	OFF	FKA
19	Rear window	OFF	IHKA
20	Heater blower	50 %	IHKA/FKA
21	Heated windshield	OFF	SMFA SMBF
22	Heater blower	25 %	IHKA/FKA

Note: All measures are implemented in the specified order.

Advanced Power Management

Energy Flow

During vehicle operation, the mechanical energy of the engine is converted by the alternator into electrical energy and made available to the electric loads. The electric loads receive their power supply mainly via terminal 30g and via terminal 30g_f.

Certain electric loads are also still supplied directly by terminal 30 or by terminal R. For example, the anti-theft alarm system (DWA) must still remain active when the vehicle is parked.

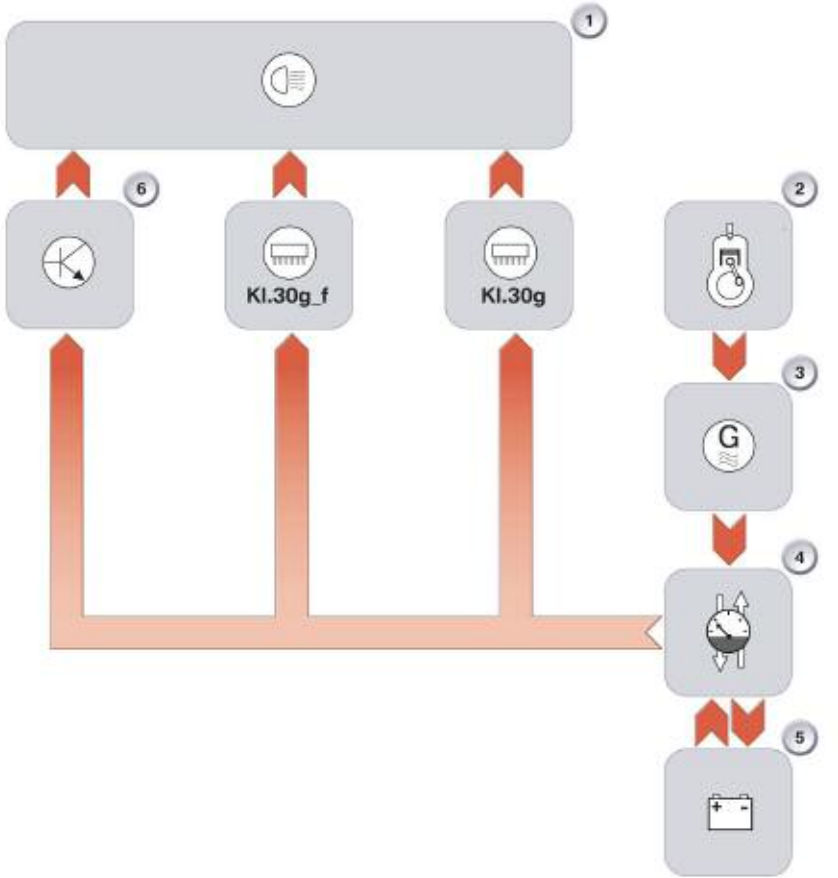

Index	Explanation	Index	Explanation
1	Electric loads	5	Vehicle battery
2	Drive motor	6	Control units
3	Alternator	KL30g	Terminal 30, switched
4	Intelligent Battery Sensor	KL30g_f	Terminal 30 switched, fault dependent

Information Flow

The calculations necessary for controlling the energy balance take place in the power management. The idle speed and charging voltage are regulated while the engine is running. The power intake of electric loads with relatively high power consumption is reduced or the loads are switched off as required.

Certain electric loads can be switched off when the engine is stationary. This takes place either time-controlled via the CAS and the terminal 30g relay or in response to electrical faults via the engine control, junction box and the terminal 30g_f relay.

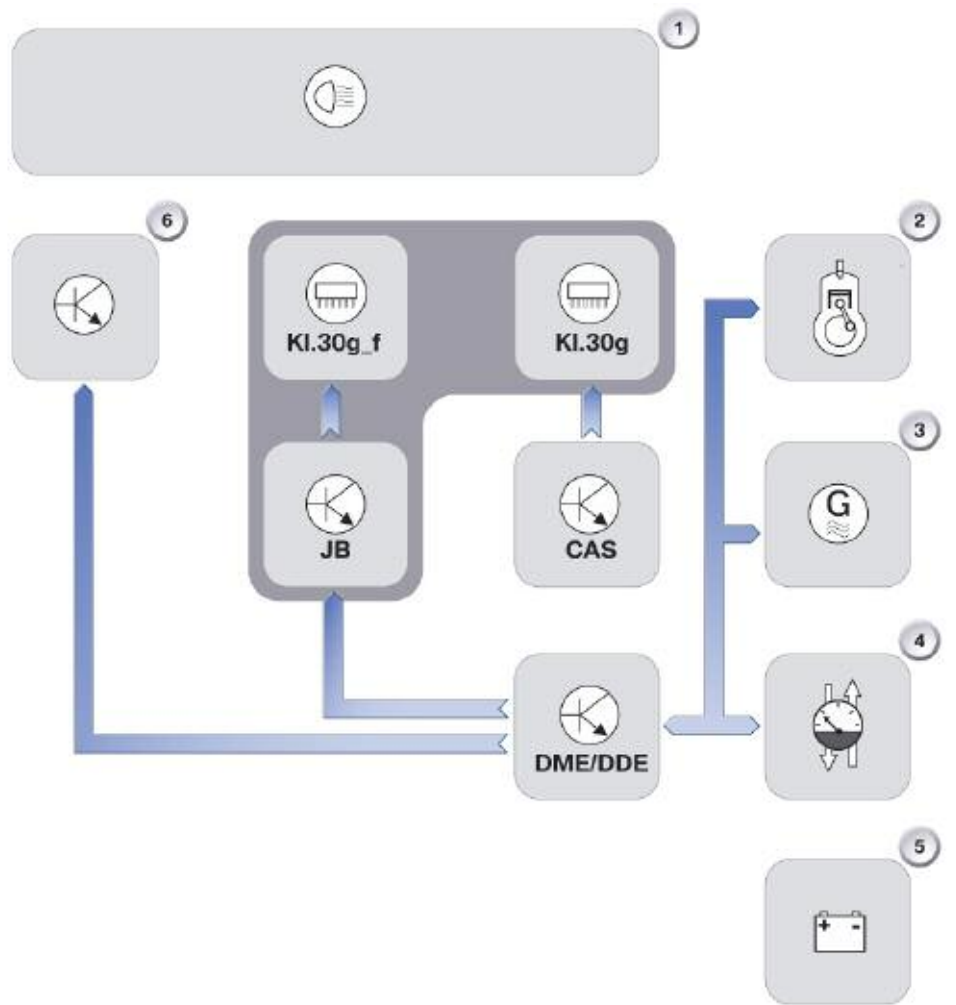

Index	Explanation	Index	Explanation
1	Electrical loads	4	Intelligent battery sensor
2	Engine	5	Vehicle battery
3	Alternator	6	Control units

Diagnosis Information

The control units for the engine management, junction box and footwell module provide various information for the purpose of realizing effective diagnosis. Information relating to the status of the vehicle battery is stored in the engine management (engine control).

Information on the functional sequences in the various bus systems is stored in the junction box. The BMW diagnosis system can access and evaluate this information. The BMW diagnosis system features an evaluation software that facilitates assessment of the history values and indicates the cause of problems as the result.

This result must be assessed by a technician in order to find the correct cause of the fault.

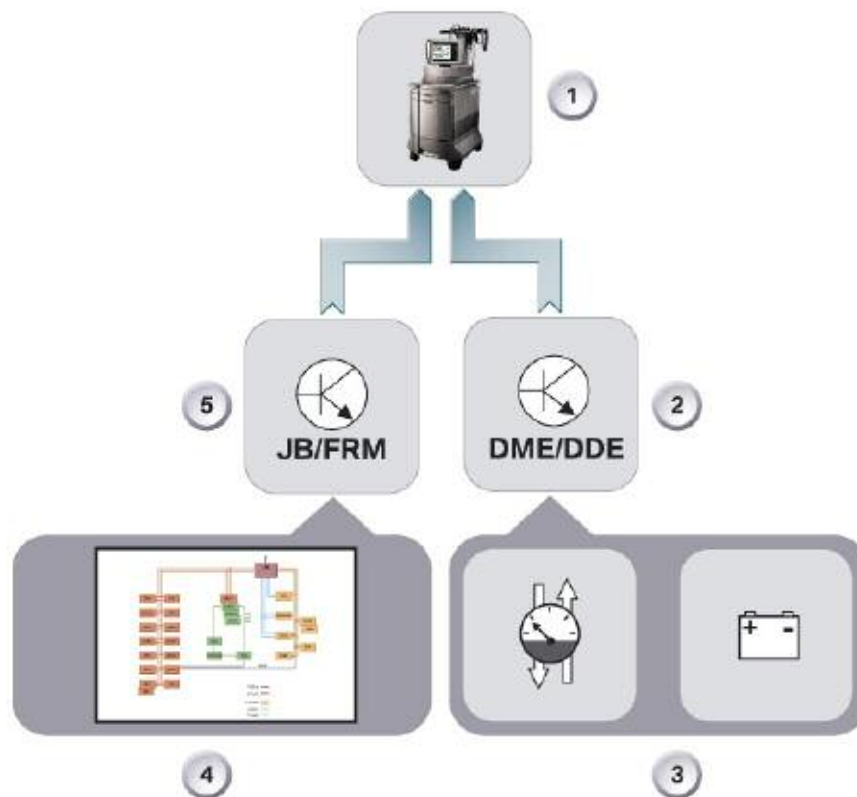

Index	Explanation	Index	Explanation
1	BMW Diagnostic system	4	Bus systems
2	Engine management	5	Junction box control unit/Footwell module
3	Vehicle battery with IBS		

Vehicle in Stationary Mode (terminal R and terminal 30)

■ Electric Loads in Stationary Mode

Certain electric loads may be active even when the closed-circuit current monitoring facility of the power management is already in operation. This is necessary for various reasons:

- Legally required electric loads, e.g. side lights, hazard warning system
- Convenience for the customer, e.g. radio function, telephone

These electric loads must be excluded from the closed-circuit monitoring system in order to avoid misinterpretation in the power management. For this purpose, these electric loads must log in with the power management.

In turn, the power management recognizes the activity and accepts the higher power consumption when the systems are deactivated, the corresponding control units log off from the power management.

■ Stationary Load Log-off

The power management in the engine control can send a request to switch off the active electric loads in stationary mode depending on the battery charge status and the start capability limit. As a result, the stationary loads must deactivate their functions irrespective of the terminal status and must reach their closed-circuit current within 5 minutes. Legally required electric loads are excluded from this function.

■ Terminal 30g and Terminal 30g_f

The E70 is equipped with various relays for switching off the power supply to most control units. There are two terminal 30g relays in the front and rear power distribution boxes. The terminal 30g_f relay in the rear power distribution box is required for the following optional equipment:

- Multi-audio system controller
- Car communication computer
- Comfort Access
- Instrument cluster
- Telephone US/telephone preparation US

The relays are controlled by following control units:

- Terminal 30g_f - activation by the junction box control unit

The calculation necessary for activating the terminal 30g_f relay takes place in two control units. The following activities are monitored in the junction box control unit:

- Invalid wake-up procedures within the bus systems
- Sleep blockers (control units that constantly keep the bus systems active)

The battery values are constantly read and evaluated in the engine control unit. The relay is also switched off when the starting capability limit of the vehicle battery is reached.

- Terminal 30g - activation by the CAS

Description	Explanation
KL15	Ignition (position 2)
KL R	Accessory (position 1)
KL 30	B+ Constant
KL 30g	B+, time dependent
KL 30 g_f	B+, fault dependent

Terminal 30g and Terminal 30g_f relay

■ Time-dependent Deactivation

The terminal 30g relay switches off the connected electric loads after 30 minutes. The after-running time is extended to 60 minutes if a telephone or auxiliary heating system is installed in the vehicle. The terminal 30g relay is activated by the CAS.

■ Fault-dependent Deactivation

The terminal 30g_f relay is activated by the junction box control unit and switches off the connected electric loads if a fault occurs. The terminal 30g_f relay is a bistable relay. Each switching status is retained even when no power is applied.

■ Terminal 30g_f Relay Switch-on and off Conditions

The terminal 30g_f relay is switched on and off under the following conditions.

Terminal 30g_f ON:

- Vehicle unlocked or
- Terminal R or
- Change in status_contact_rear_hatch or change in status_door_contact_FAT/BFT/FATH/BFTH

Terminal 30g_f reset takes place:

- On reaching the upper start capability limit (start capability limit plus buffer for discharging in stationary mode).
- When the vehicle does not assume sleep mode for 5 minutes (codeable) after sending the power down command (command for all control units to assume sleep mode) without a switch-on condition being applied.
- When the vehicle is woken 10 times after switching off terminal 30g without a switch -on condition being applied. An after-running period of 2 minutes applies in this case.

Terminal 30g_f OFF:

- Bus activity 10 minutes after reset without a switch-on condition being applied.
- Vehicle is woken 5 times without a "switch on" condition being applied.
- "Signal OFF" received. Terminal 30g_f relay is switched off after 2 minutes.

The terminal 30g_f relay is a bistable relay and is always in the ON state under normal conditions. It switches off the connected electric loads only in the case of fault. Once the terminal 30g_f relay has been switched off, one of the switch-on conditions is necessary in order to switch it on again.

Note: Switching terminal 30g_f results in a reset of the instrument cluster.
This means the time must be reset again.

■ Continuous Positive

As before, various electric loads are connected directly to terminal 30. The PDC control unit is connected to terminal 15.

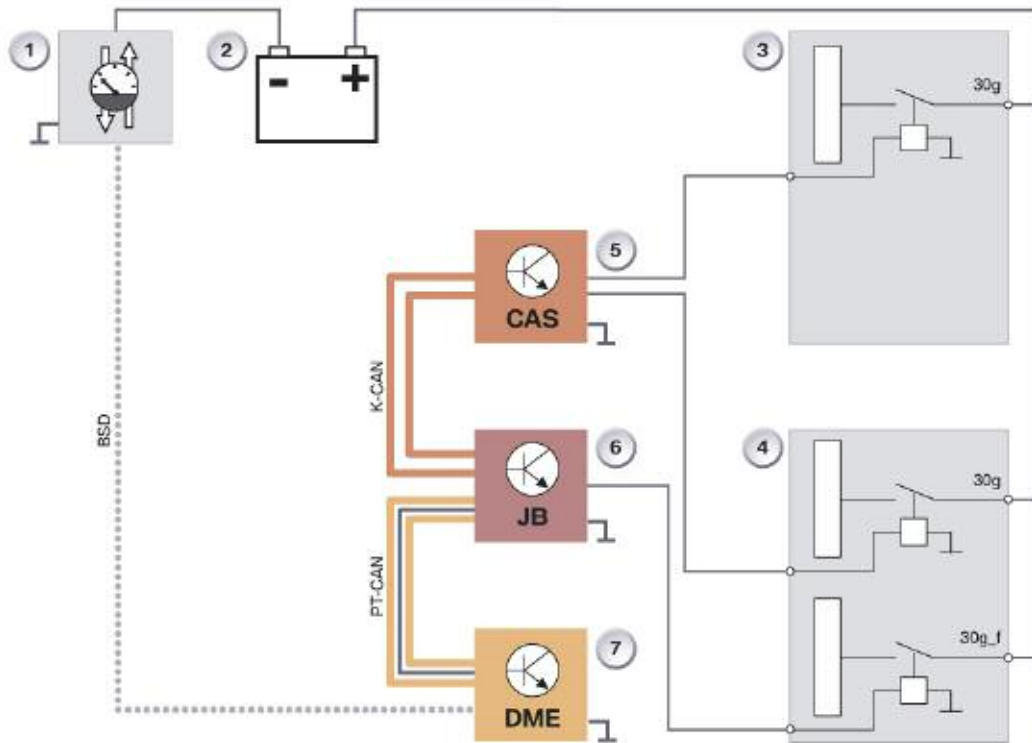

Index	Explanation	Definition/Function
1	IBS	Monitors voltage, current and temperature
2	Vehicle battery	Supplies power via the power distribution boxes to the individual loads
3	Front power distribution box with terminal 30g relay	Equipped with one relay for load shutdown (KL30g)
4	Rear power distribution box with KL30g and KL30g_f relays	Equipped with two relays for load shutdown (KL30g and KL30g_f)
5	CAS 3	Responsible for controlling KL30g relay in the power distribution boxes
6	Junction Box Control unit	Responsible for controlling the KL30g_f relay
7	Digital Motor Electronics	Responsible for evaluating the measured data of the IBS and requests activation by the junction box control unit as required. When the charge status of the battery is low, at "terminal R OFF", the engine management additionally sends a request to switch off terminal 30g to the CAS.

General Measures

The terminals "load shut-down" and the terminal "interior lighting" are switched off as a general measure when the vehicle is in stationary mode. This occurs only when the vehicle is not locked and secured. These loads are shut down immediately when the vehicle is locked and secured.

This measure affects the following electric loads:

Electric Loads	Terminal
Interior lighting (front and rear)	Load shut-down after 8 minutes (immediately if locked)
Footwell lighting (front and rear)	Load shut-down after 8 minutes (immediately if locked)
Reading light (front and rear)	Load shut-down after 8 minutes (immediately if locked)
Vanity mirror light	Load shut-down after 8 minutes (immediately if locked)
Terminal R	Load shut-down 8 minutes after opening door (immediately if locked, only on vehicles with Comfort Access)
Terminal R	Load shut-down after 2 minutes at poor battery charge status (immediately if locked, only on vehicles with Comfort Access)
Light (switch position 2 - low beam)	Load shut-down after "terminal R OFF" and door open

Components

The energy management consists of the following components:

- Combustion engine
- Alternator
- Vehicle battery
- Intelligent battery sensor (depending on equipment)
- Junction box
- Engine management (power management)
- Loads

The most important components of the energy management system are described in the following.

Intelligent Battery Sensor (IBS)

The intelligent battery sensor has the same scope of functions as the intelligent battery sensor in the predecessor models.



Index	Explanation	Index	Explanation
1	Ground lead	3	BSD Interface
2	Connection, B+	4	IBS

The software in the IBS controls the functional procedure and communication with the higher-ranking control unit (engine management). During vehicle operation, the IBS sends data via the bit-serial data interface (BSD) to the engine management.

Among other things, the following main functions are integrated in the IBS:

- Continuous measurement of the battery current, voltage and temperature under all vehicle operating conditions. When the vehicle is stationary, the measured values are checked cyclically in order to save power. The IBS is programmed such that it wakes up every 40 seconds. The IBS measurement time is approximately 50 ms. The measured values are entered in the closed circuit histogram in the IBS. In addition, the battery charge status (SoC) is partly calculated. The DME reads out the histogram after restarting the vehicle. A corresponding fault code is entered in the DME fault code memory in response to a closed-circuit current transgression. The data are transmitted via the bit-serial data interface.
- Calculation of the battery indicators as the basis for the charge and health status of the battery. The battery indicators are charge and discharge current, voltage and temperature of the vehicle battery.
- Balancing of the charge/discharge current of the battery.
- Continuous monitoring of the battery charge status and making available the corresponding data in the event of insufficient battery power.
- Calculation of the current progression when starting the engine to determine the battery health status.
- Closed-circuit current monitoring of the vehicle.
- Self-diagnosis.

Junction Box

The junction box control unit is responsible for the fuse of the terminal 30g_f relay and for storing information (history data and fault code entries) in the area of the energy management. As part of vehicle diagnostics, these data can be used to evaluate faults and to analyze the vehicle battery.

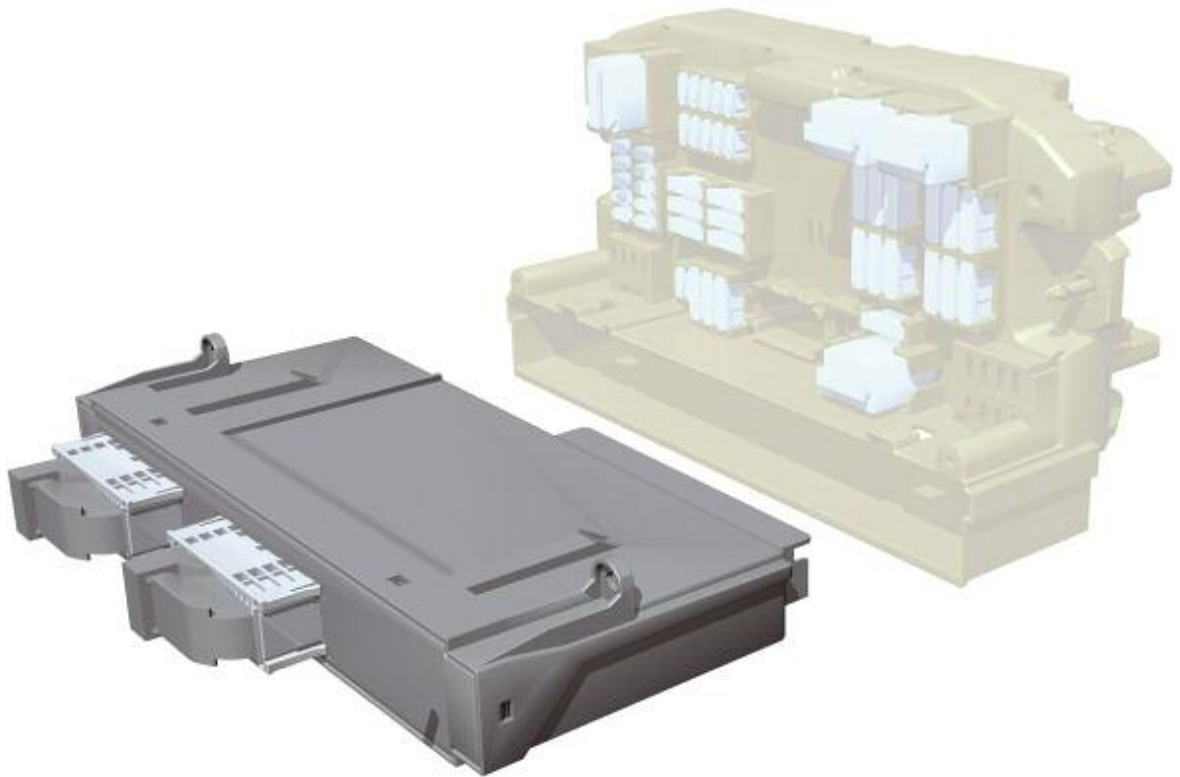

Engine Management (Power Management)

The (power management) software for controlling the energy balance is located in the engine management. Based on this control, various electric loads in the vehicle systems network are switched on and off via the CAS control units, relay terminal 30g or via the junction box, relay terminal 30g_f. The power management is additionally responsible for evaluating and storing the IBS data.



Transport Mode

The following functions are switched off and on in the E70 in transport mode:

- 0 = Function is switched off
- 1 = Function is switched on or changed

Index	Function	Control Unit	Transport Mode
1	Power window (front passenger's door)	FRM	0
2	Mirror heating High (driver's/front passenger's door)	FRM	0
3	Home lighting	FRM	0
4	Side light in switch position "A" + "2" (at terminal 0 + R)	FRM	0
5	Parking light (at terminal 30)	FRM	0
6	Limiting load shut-down time from 8 minutes to 1 minute (vanity mirror, reading lights, the interior light is also switched off)	FRM	1
7	Pre-sleep mode	FRM	0
8	Turn-off light	FRM	0
9	Welcome light	FRM	0
10	Power window (rear driver's side)	FRM	0
11	Power window (rear passenger's side)	JB	0
12	Headlight washer system (SRA)	JB	0
13	Seat heating Low (driver/front passenger)	JB	0
14	Rear window wiper	JB	0
15	Rear window washer system	JB	0
16	Mirror heating Low	JB	0
17	Disconnection terminal 30g_f_1 + terminal 30g_f_2 after 5 minutes	JB	1
18	Radio remote control (including rear hatch unlock)	CAS	0
19	Limitation of terminal 30g - time from 30 min or 60 min to 5 min	CAS	1
20	Reducing terminal R active time from 16 min to 2 min, irrespective of operating status of door contact	CAS	1
21	Comfort Access, complete function	CAS	0
22	Slide/tilt sunroof	FZD	0
23	Panoramic glass roof	FZD	0
24	DWA function	FZD	0
25	Rear window defogger	IHKA	0
26	Blower; limitation to max. 50 % Attention: No limitation when DEFROST button pressed, i.e. 100 % blower output possible.	IHKA	1
27	Defrost (100 % blower output possible)	IHKA	1
28	Water pump, water valves, compressor	IHKA	0
29	Electric auxiliary heater (PTC)	IHKA	0
30	Steering wheel heating	IHKA	0

Index	Function	Control Unit	Transport Mode
31	Auxiliary ventilation function	IHKA	0
32	Independent ventilation function	IHKA	0
33	Electric steering column adjustment	IHKA	0
34	Not used	IHKA	0
35	Electric auxiliary fan, 3rd row of seats	IHKA	0
36	Seat heating, rear compartment	FKA	0
37	Electric auxiliary fan, 2nd row of seats	FKA	0
38	All rear blowers	FKA	0
39	Car communication computer Operation + MOST deactivated	CCC	0
40	M-ASK 2-NAV operation + MOST deactivated	M-ASK 2-NAV	0
41	CHAMP (all versions)	CHAMP	0
42	Rear compartment entertainment	RSE	0
43	Central information display, front	CID	0
44	Central information display, rear	CID_R	0
45	Central operating unit	ZBE_high ZBE_low	0
46	Bluetooth interface	TCU	0
47	Telematics function	TCU	0
48	Emergency call function	TCU	0
49	Telephone control, prevent wake-up of MOST bus	TCU	0
50	Seat heating High (driver/front passenger)	SM	0
51	Lumbar support	SM	0
52	Active seat ventilation	SM	0
53	Active seat	SM	0
54	RFK (reversing camera)	RFK	0
55	Not used		0
56	Comfort Access, deactivation of TAGS	PGS	0
57	Reducing outside temperature measurement	Kombi	0
58	HUD (Head-up display)	HUD	0
59	Damper control (valves + compressor)	EHC	0
60	Idle speed boost (upper idle speed value)	DME	1
61	Maximum charging voltage (+14.8 V to 40 °C)	DME	1
62	Deactivating IGR function	DME	0

Closed-circuit Current

The closed-circuit current on the E70 is approximately 22 mA on fully equipped US vehicles.

A check control message is sent as from a closed-circuit current value of 80 mA (increased battery discharge when the vehicle is stationary).

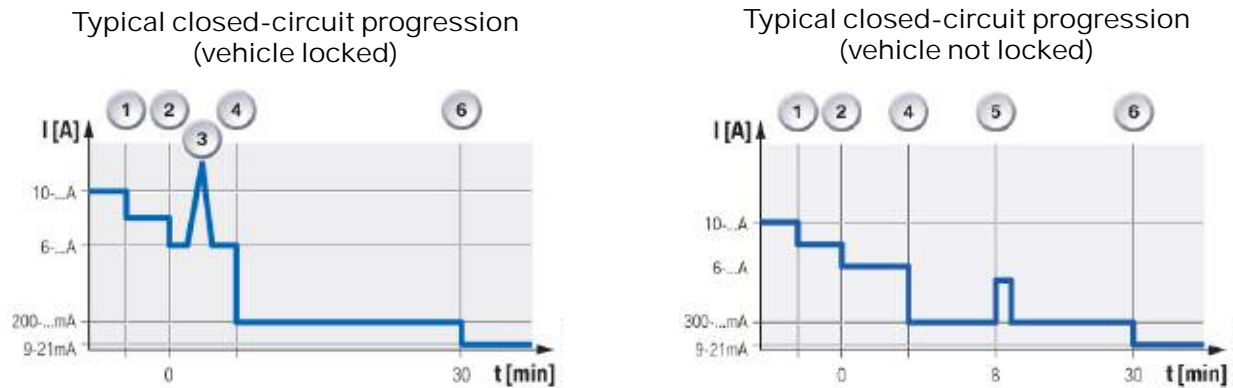

Index	Explanation
1	Terminal 15 OFF
2	Terminal R OFF
3	Vehicle is secured
4	Start of bus rest phase
5	Electric load shutdown after 16 minutes
6	KL30g OFF (30 min without or 60 min with telephone)

The preceding diagram shows a typical closed circuit current progression in the E70 in connection with the various operating modes in the vehicle electrical system. The actual current values change depending on the vehicle equipment configuration.

The terminal "load shut-down" (e.g. reading light and vanity mirror light) is switched off corresponding to the terminal status.

Load shut-down switches off immediately when the vehicle is secured. In all other terminal statuses, terminal "load shut-down" is switched off after an after-running time of 8 minutes. It is activated by the footwell module.

Note: The closed-circuit current should always be measured if increased current consumption is suspected.

Even current consumption rates slightly elevated above the normal can discharge the battery at a relatively fast rate.

Electrical System and Battery Diagnosis

Over the past few years, the energy management of all BMW models has been continuously improved and standardized across the various model series. In terms of energy diagnosis, this also means standardization of testing schedules and displays in the BMW diagnostic system.

The aim of the diagnostic procedures is to show the causes of a discharged battery as unambiguously as possible. In view of the complexity, especially in the area of energy management, the specific cause of a fault can be shown only partially depending on its nature.

The acquired energy diagnosis data are shown if the fault cannot be clearly assigned based on the acquired data. The number of bus wake-ups (up to 254) and up to 50 bus wake-up IDs (control unit responsible for the wake-up procedure) are shown. The bus wake-ups are recorded in the E70 by means of the junction box control unit with a co-processor.

This information is shown only if a fault is suspected in this area. The revised test module has been available since DIS CD43 for most BMW models. The junction box control unit features a history memory that is also used in the energy diagnosis process. The junction box records bus wake-ups of the K-CAN while the vehicle is at rest. Recording the bus wake-ups is a new function, which is integrated in the energy management of the E70.

The junction box control unit is equipped with a separate controller for the purpose of recording the bus wake-ups. This controller is necessary so that the main processor of the junction box control unit can assume sleep mode.

Power management is retained in full while the expanded diagnostic options are now resident in the history memory. The following overview lists the energy management control procedures for the E70. Many options are available in the E70 of assessing the energy management in connection with the BMW diagnostic system.

Energy Management - Diagnosis in Vehicle

Various values from the vehicle system network are measured and, in part, also evaluated directly in the vehicle. This information on the battery status or on the behavior of the bus systems can then be subsequently compiled and evaluated in the BMW diagnostic system. The following values are recorded in the vehicle:

Energy management in the E70	
Power management	History memory
Closed-circuit current	Sleep blockers
State of Charge SoC	Bus wake-up
State of Health SoH	Bus wake-up ID (new)
	Driving profile/stopped profile



Vehicle control while in operation :

- Electric load shut-down/reduction
- Alternator voltage
- Idle speed boost

Vehicle control while at rest::

- Terminal 30g
- Terminal 30g_f
- Stationary load management

The data from the energy management are used not only for controlling the energy balance in the vehicle but also for diagnostic and vehicle servicing purposes.

The following overview shows the data that are displayed in DIS for diagnosis and servicing.

Data acquisition and calculation in energy management for the E70	
Power management	History memory
Closed-circuit current	Sleep blockers
State of Charge SoC	Bus wake-up
State of Health SoH	Bus wake-up ID (new)
	Driving profile/stopped profile



Diagnosis and Servicing

- Display of last 32 closed-circuit current values (measured 120 minutes after "Terminal R OFF" up to next "Terminal R ON")
- Display of sleep blockers (max. 5 sleep blockers with relative time and km-reading)
- Display of driving profile/stopped profile (miles driven over acquisition period)

New Displays:

- Display of number of bus wake-ups (max. 254 bus wake-ups are counted and displayed)
- Display of bus wake-up IDs (max. 50 bus wake-ups with relative time and km-reading)

Energy History Memory

The energy history memory enables differentiated evaluation and display of energy diagnosis. For instance, bus wake-ups can be read out and displayed together with their IDs.

A distinction is made between three definitions when considering the functional principle of the history memory.

- Memory cycle
- Data record
- Ring memory

■ Memory Cycle

One single memory cycle ranges from switching on through to repeated switching on of terminal R.

The following information is recorded during the memory cycles:

- Driving profile and stopped profile
- Sleep blockers
- Bus wake-up
 - Number of bus wake-ups
 - Bus wake-up ID

■ Driving Profile and Stopped Profile

The driving profile shows the driver's driving characteristics in terms of frequency of certain driving distances (long and short trips). The recording begins as from "KLR-ON" and ends with "KLR - OFF".

The stopped profile test module contains the data that are stored as from "KLR - OFF" up to "KLR - ON". The stopped profile makes it possible to draw conclusions with regard to the duration of vehicle rest phases.

The history memory has memory areas for sleep blockers, number of bus wake-ups and bus wake-up IDs. The memory areas comprise ring memories. The relative time and mileage reading generally accompany the memory areas. The corresponding control units are also listed in the area of the sleep blockers and bus wake-up IDs.

The driving profile is stored in the area for the number of bus wakeups.

Sleep Blockers

Control units that do not assume sleep mode are known as sleep blockers. Each control unit signals its readiness to assume sleep mode to the junction box control unit by periodically sending a sleep indication bit. The energy diagnosis testing schedule in the BMW diagnostic system generally interprets this information as an "intact control unit".

If the "sleep indication bit" is not received, the corresponding control unit is stored in the history memory of the junction box control unit and displayed when working through the "Energy diagnosis" testing schedules.

Monitoring involves the following procedure:

- Monitoring of sleep blockers after "Terminal R OFF"
- Monitoring of sleep blockers after "Terminal 30g OFF"
 - Power-down command and monitoring of sleep blockers
 - Terminal 30g_f reset and monitoring of sleep blockers
 - Terminal 30g_f shut-down and monitoring of sleep blockers

The fault code memories are checked after each measure. This facilitates allocation that makes it possible to differentiate fault locations with respect to the terminals.

Note: Customer operating procedures (radio etc. at "Terminal R OFF") can also lead to a fault code entry.

The wake-up line should be checked especially if several control units from the PT-CAN do not assume sleep mode (at "Terminal R OFF" < 2 V).

■ Bus Wake-ups

Control units that wake up the entire bus system are known as bus wake-ups. Frequent wake-ups by all control units in the bus system places an excessive load on the vehicle battery.

Bus wake-ups can be caused by defective control units or their peripherals.

Bus wakeups occur, however, also when the vehicle is fully intact. This is due to the fact that a bus system has to be woken in connection with certain functions when the vehicle is at rest, for example:

- To record the outside temperature
- To switch off the load shut-down function

The junction box control unit registers the bus wake-ups of the K-CAN in the period between "Terminal R OFF" and "Terminal R ON". The following data are stored:

- Number of bus wake-ups
 - A maximum of 254 bus wake-ups can be stored
- Bus wake-up ID
 - The control unit can be identified by the bus wake-up ID. The relative time (comparable with operating hours counter) and the km-reading are also stored. The relative time is made available by the instrument cluster.

The bus wake-ups can be read out as part of the diagnostic procedure. However, it is not possible to distinguish whether the bus wakeup is authorized or unauthorized. For this reason, the authorized bus wake-ups are taken into account when assessing the bus wake-ups in the diagnostic procedure.

Note: It is possible to distinguish between the individual control units only in K-CAN. Outside the K-CAN, a fault can be assigned to the respective bus systems.

Intact Vehicle

The "intact vehicle" graphic shows the memory cycle on a fully intact vehicle. All control units and the data bus itself are in sleep mode. No data communication takes place between the individual control units. The entire bus system is woken at certain intervals.

Responsible for this are:

- FRM - The FRM sends the request to shut down the electric loads after 8 minutes only if the vehicle is not locked. Otherwise, the electric loads are switched off immediately when the vehicle is locked and secured.
- KOMBI - Whenever the DME checks the coolant temperature, the outside temperature is also calculated at this time from the outside temperature sensor and stored in the KOMBI.
- CAS - When terminal R is switched on repeatedly.

Defective Vehicle

The "defective vehicle" graphic shows the memory cycle on a defective vehicle. If a fault is present, a distinctly higher number of wakeups will occur in the control unit rest phase. One or several control units sporadically wake up the entire bus system due to unwanted data communication (red). The new options in the junction box control unit make it possible to show the bus wakeups in the BMW diagnostic system.

The display is activated if the number of bus wakeups amounts to more than 20.

The BMW diagnostic system is only capable of distinguishing between control units (systems) in terms of faults that occur in the area of the sleep blockers and bus wakeups. More extensive diagnosis must be performed if a component in the peripherals of the control unit is indirectly responsible for the entry in the fault code memory.

Replacing the respective control unit will not remedy the problem in this case.

Example:

A defective Hall sensor in the key slot can cause fault code "Sleep blocker CAS" to be entered. The cause is therefore in the input of the control unit that has wake-up capabilities and not in the control unit itself.

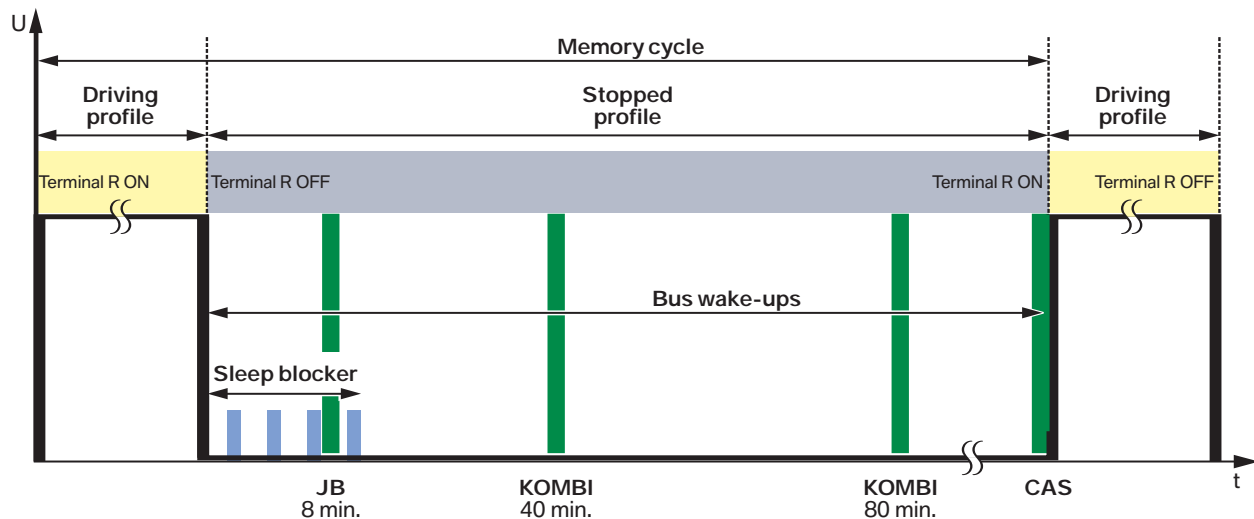
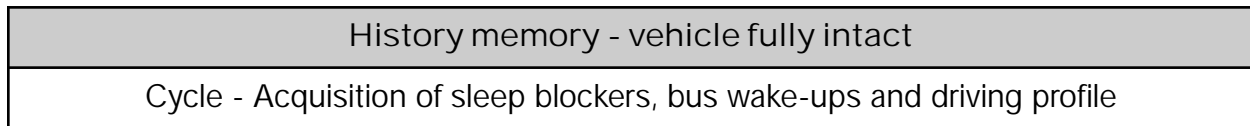

History memory - vehicle defective

Cycle - Acquisition of sleep blockers, bus wake-ups and driving profile

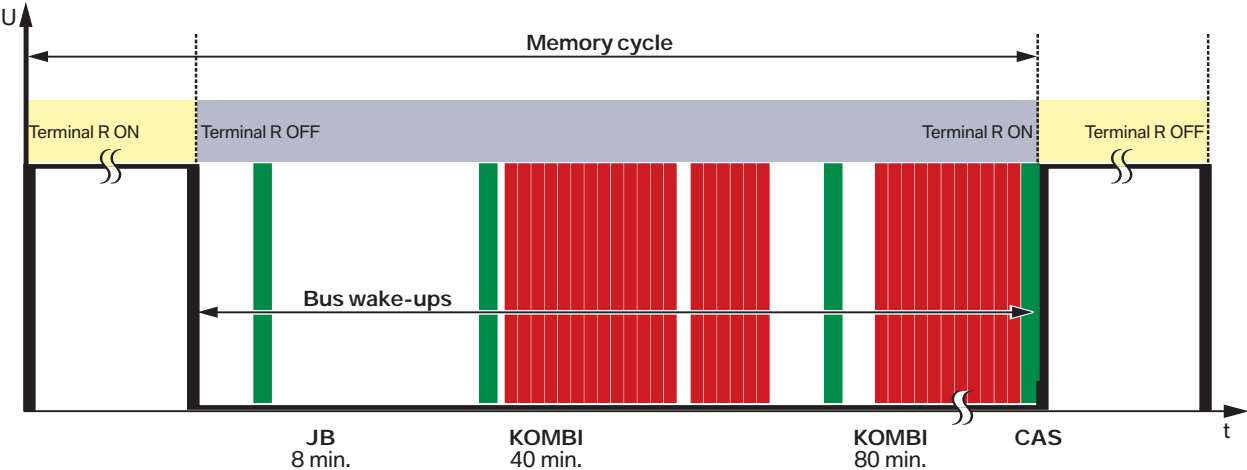

Index	Explanation	Index	Explanation
Memory cycle	Memory cycle	Bus wake-ups	Bus wake-ups
Driving profile	Driving profile	Sleep blocker	Sleep blockers
Stopped profile	Stopped profile	KLR ON/OFF	Terminal R ON/OFF
JB	Junction box control unit	CAS	Car Access System
Kombi	Instrument cluster		

Besides unauthorized bus wake-ups, authorized bus wake-ups are also possible. Possible authorized bus wake-ups are defined in the following table.

Control unit	Possible reasons for wake-ups (authorized bus wakeups)
Car Access System	<ul style="list-style-type: none"> • START-STOP button pressed • Remote control/identification transmitter ejected from slot • Center lock button pressed • Remote control operated • Hood contact switch • Hotel position switch • Front left and front right door handle contact • Wake-up line
Junction box control unit Footwell module	<ul style="list-style-type: none"> • Electric load shut-down • Rear left and rear right door contact • Rear hatch button and rear hatch lock • Interior light button
Junction box control unit	<ul style="list-style-type: none"> • Front left and front right door contact • Front left door lock • Wake-up line
Instrument cluster	<ul style="list-style-type: none"> • Coolant temperature query at DME • Programmed timer for independent heating function, independent ventilation function and independent climate control elapsed
Footwell module	<ul style="list-style-type: none"> • Hazard warning switch
CHAMP CCC	<ul style="list-style-type: none"> • Rotary push button for volume control pressed
Anti-theft alarm system	<ul style="list-style-type: none"> • Audible and visual alarm triggered
Steering column switch cluster	<ul style="list-style-type: none"> • Steering column stalk, left or right direction indicator • Headlight flasher

Data Record

The history memory is subdivided into 3 memory areas:

- Memory for sleep blockers
- Memory for number of bus wake-ups and driving profile/stopped profile
- Bus wake-up IDs

■ Sleep Blockers

The memory for the sleep blockers is a ring memory. It can store up to 5 data records. After "Terminal R OFF" or after a bus wakeup, the junction box control unit registers the sleep blockers for a period of 20 minutes. For this purpose, the junction box control unit checks via the K-CAN and PT-CAN at 5 minute intervals whether all control units have sent a sleep mode message.

The corresponding sleep blocker (control unit) is stored, if a control unit has not sent a sleep mode message. Information contained in the data record includes:

- Control unit that was recognized as a sleep blocker
- Mileage-reading
- Relative time

■ Number of bus wake-ups, driving profile/stopped profile

The number of bus wake-ups as well as the driving profile and stopped profile are stored in the second memory area. A maximum of 254 wake-ups can be counted and shown.

The data are written to a data record over a period of 168 hours (one week). A new data record is created after this period of time has elapsed. A total of 6 data records can be stored in a ring memory. The oldest data record drops out of the ring memory when a new data record is created.

The data record contains following information:

- Number of bus wake-ups
- Mileage reading
- Relative time
- Driving profile/stopped profile

Bus Wake-up IDs

Bus wake-up IDs are stored in the third memory area. This memory area has capacity for 50 entries and is also designed as a ring memory.

The following information is stored:

- Control unit that caused the bus wake-up and the CAN-ID
- Mileage reading
- Relative time

The measured values from the energy management are transferred to the corresponding memory modules. Evaluation takes place as soon as a new memory cycle is transferred. The new memory cycle will be stored, if the number of bus wake-ups is greater.

The data from the previous memory cycle are retained if the number of bus wake-ups is less than the previous memory cycle when a new memory cycle is transferred.

■ Data Record Storage

Each data record has an acquisition period of 7 days. A new data record is generated when the following conditions apply:

- A period of 7 days has elapsed
 - The 7 day period represents normal vehicle operation.
- Battery reset
- Switching off via terminal 30g_f
 - The instrument cluster receives its power supply from terminal 30g_f. Switching off terminal 30g_f causes the relative time to be restarted. A new data record is created every time the relative time is restarted.

Note: A battery reset and restart of the relative time results in a new data record and therefore in data loss.

Ring Memory

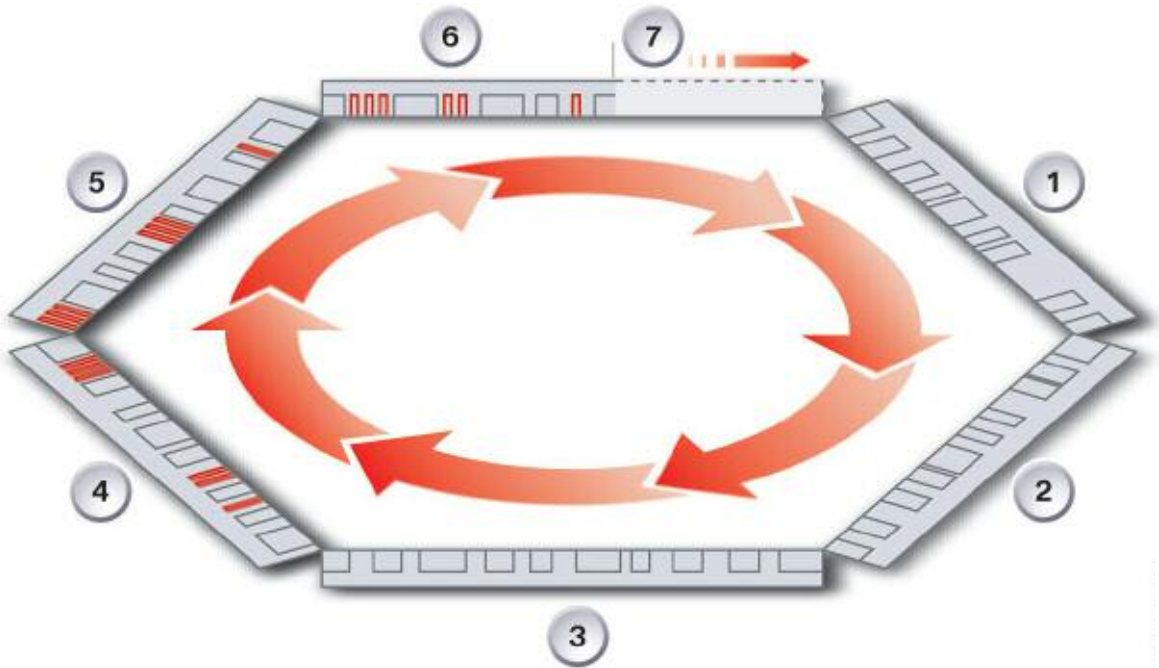

Index	Explanation
1	Data record of the first week without K-CAN bus wake-ups
2	Data record of the second week without K-CAN bus wake-ups
3	Data record of the third week with K-CAN bus wake-ups
4	Data record of the fourth week with K-CAN bus wake-up recording
5	Data record of the fifth week with K-CAN bus wake-up recording
6	Data record of the current week with K-CAN bus wake-up recording
7	Current status of K-CAN-bus wake-up recording